

TL 220SL,

passend für:
PROXIMA

6441, 7441, 8441,
8541, 9541, 10541

Trac - Lift 

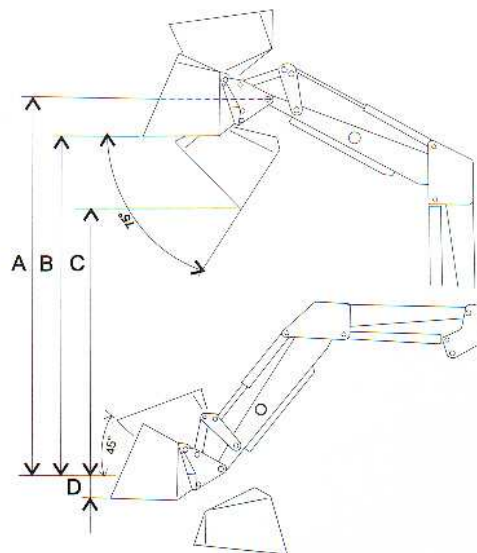

TL 220SL

A - Max. Hubhöhe am Werkzeugdrehpunkt (mm)	3 700
B - Max. Hubhöhe am unteren Werkzeugrand (mm)	3 350
C - Max. Auskipphöhe (mm)	2 800
D - Max. Arbeit unter Flur (mm)	150

Hubkraft am Schnellwechselrahmen unten (kg)	2 300
Hubkraft am Schnellwechselrahmen oben (kg)	1 700
Min. Hubkraft auf Palettengabeln 0,6 m vorn (kg)	1 250

Max. Auskippwinkel oben	75
Max. Auskippwinkel unten	45

TL 220SL,

